



Hochschule für Technik
und Wirtschaft Berlin

University of Applied Sciences

Photovoltaik-Batteriesysteme: Trends und Testergebnisse

Johannes Weniger, Nico Orth, Lucas Meissner
Forschungsgruppe Solarspeichersysteme
solar.htw-berlin.de

Fachtagung des Landesinnungsverbandes der
Elektro- und Informationstechnischen
Handwerke Berlin/Brandenburg | 01.07.2022

Entwicklung des Markts für PV-Speichersysteme in Deutschland

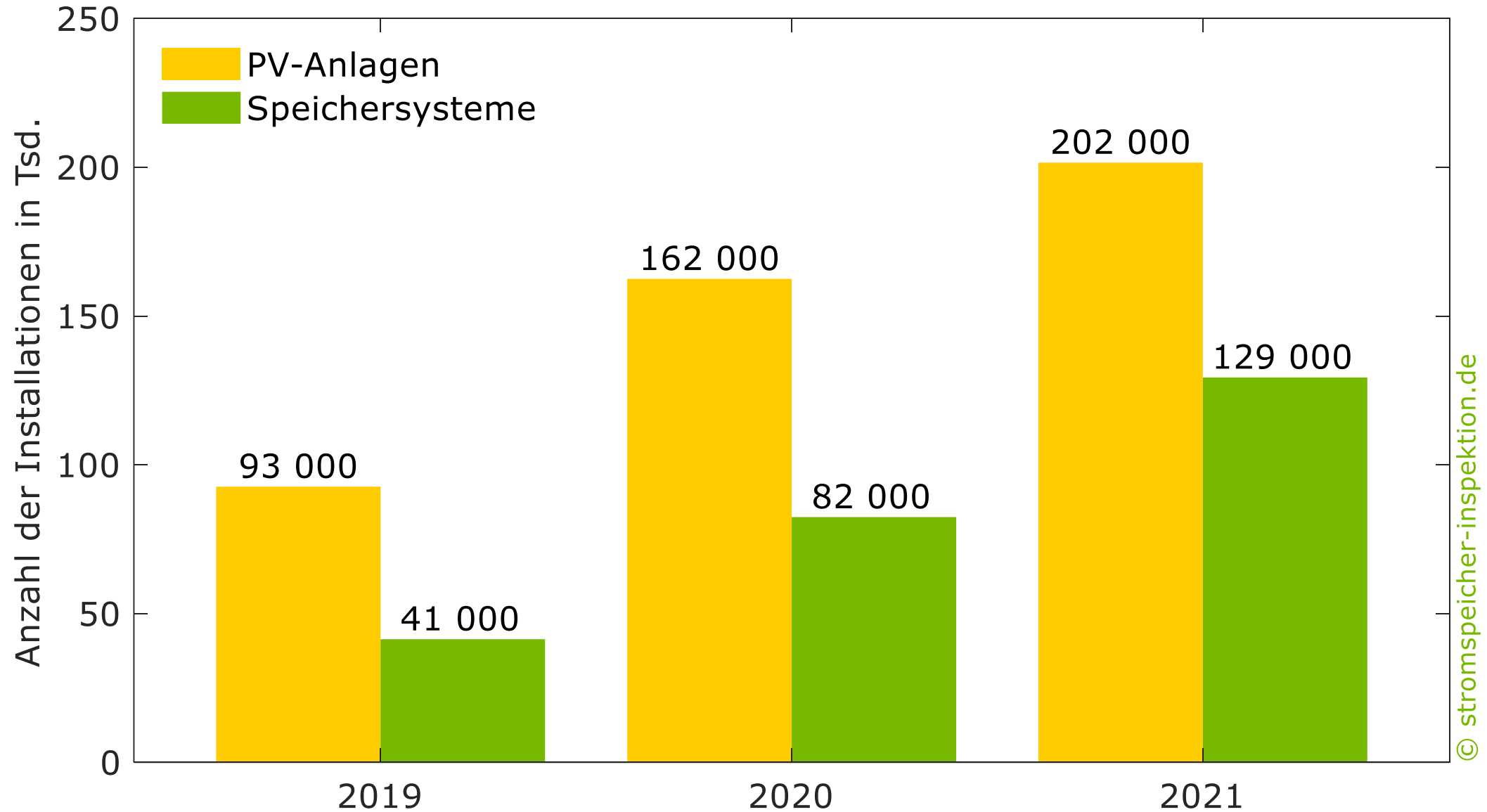

Trend #1 Die installierte Leistung der PV-Anlagen steigt

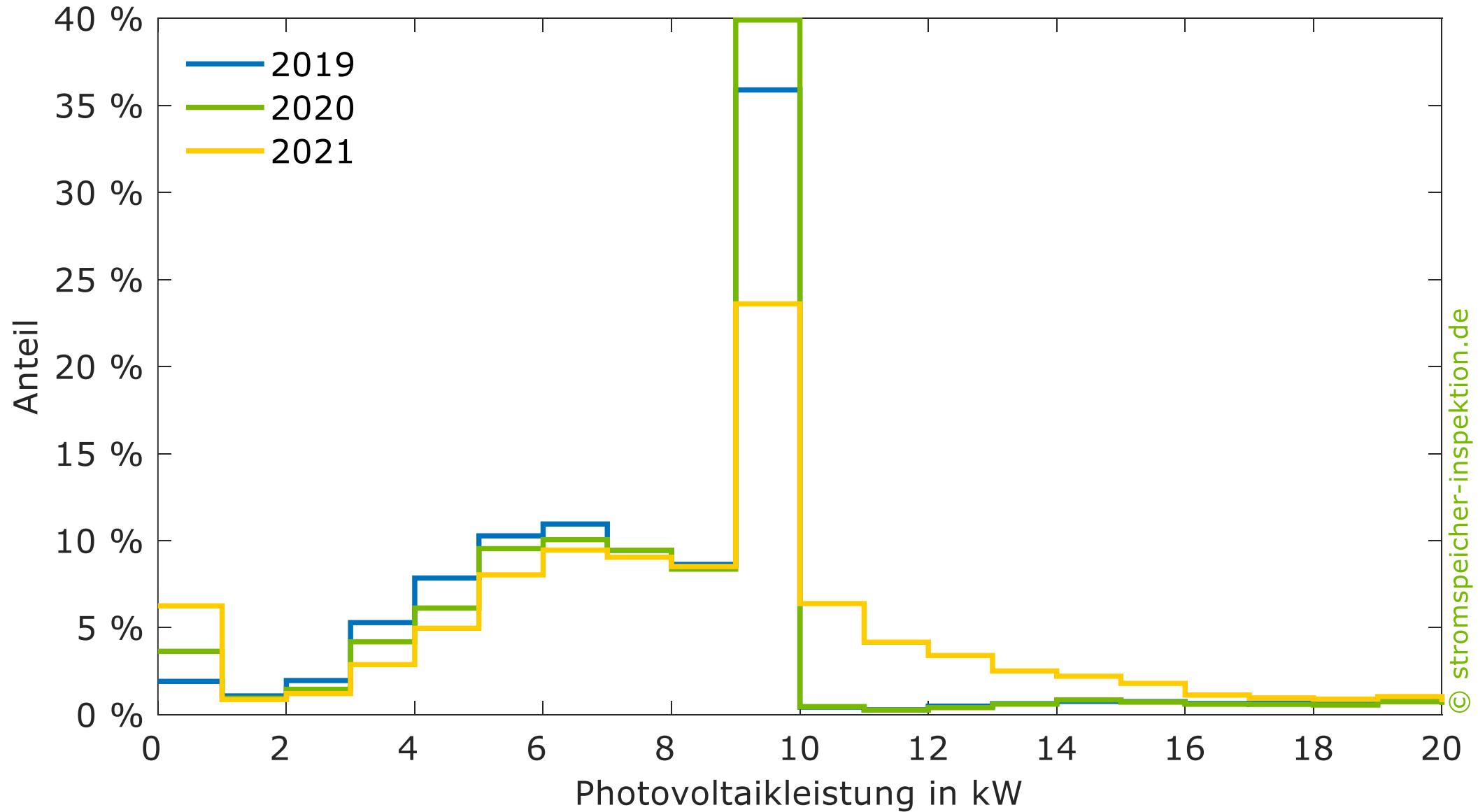

© stromspeicher-inspektion.de

Trend #2 Die Hersteller setzen auf größere Batteriemodule

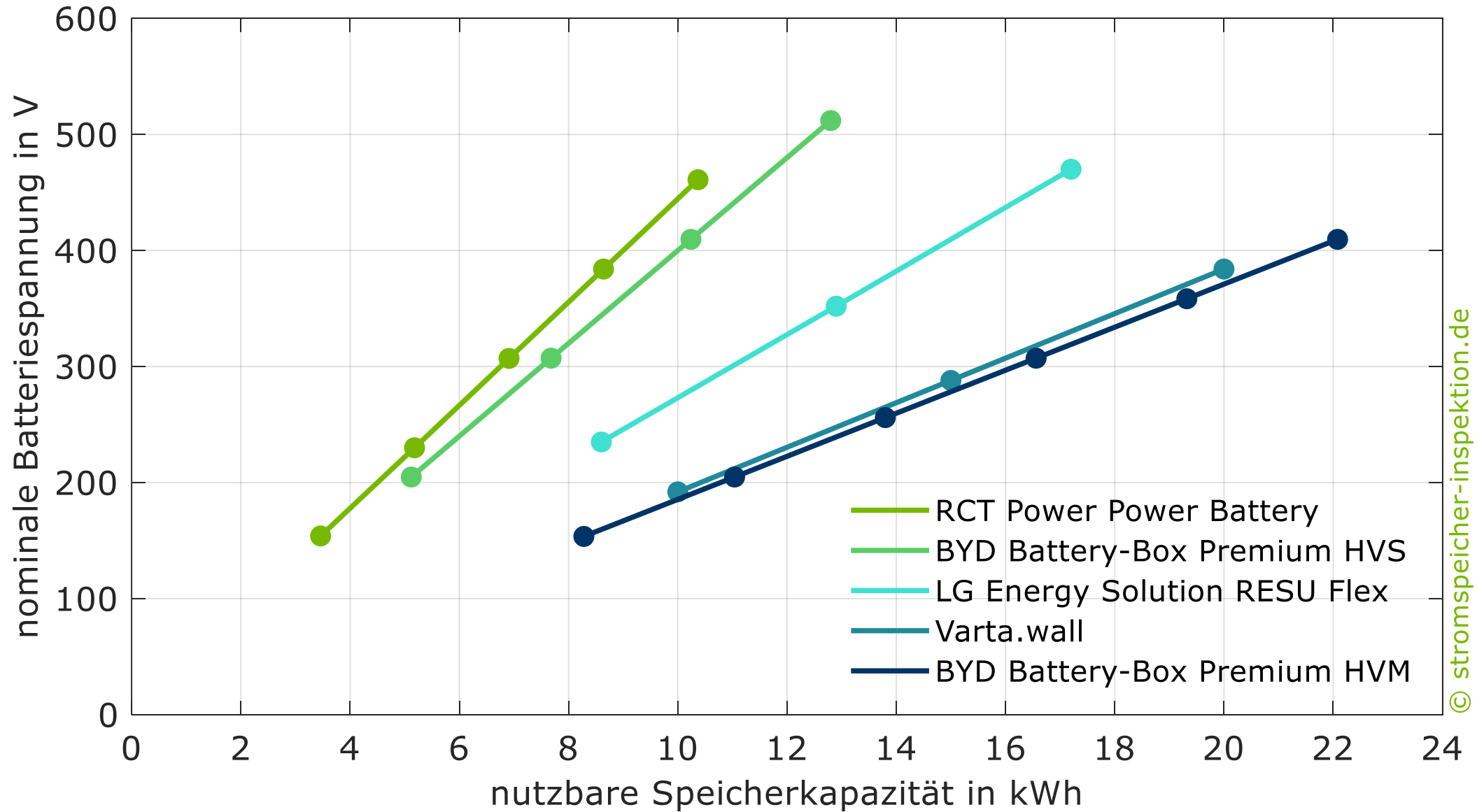

© stromspeicher-inspektion.de

Trend #3 Lithium-Eisenphosphat-Batterien dominieren den Markt

Anteil an den in Deutschland verkauften Lithium-Batteriesystemen

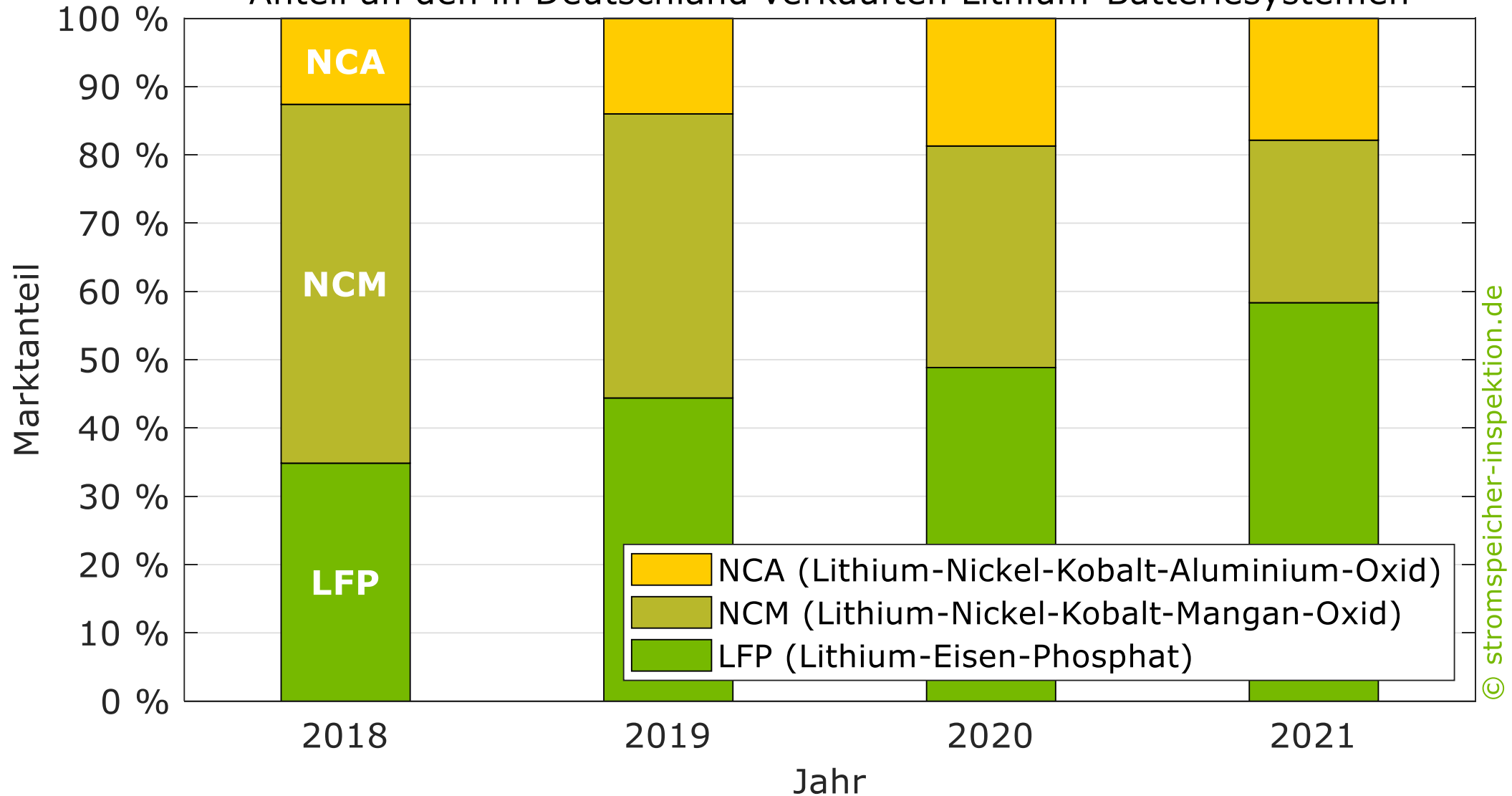

Trend #4 DC-gekoppelte Systeme setzen sich vermehrt durch

AC-gekoppelte Systeme

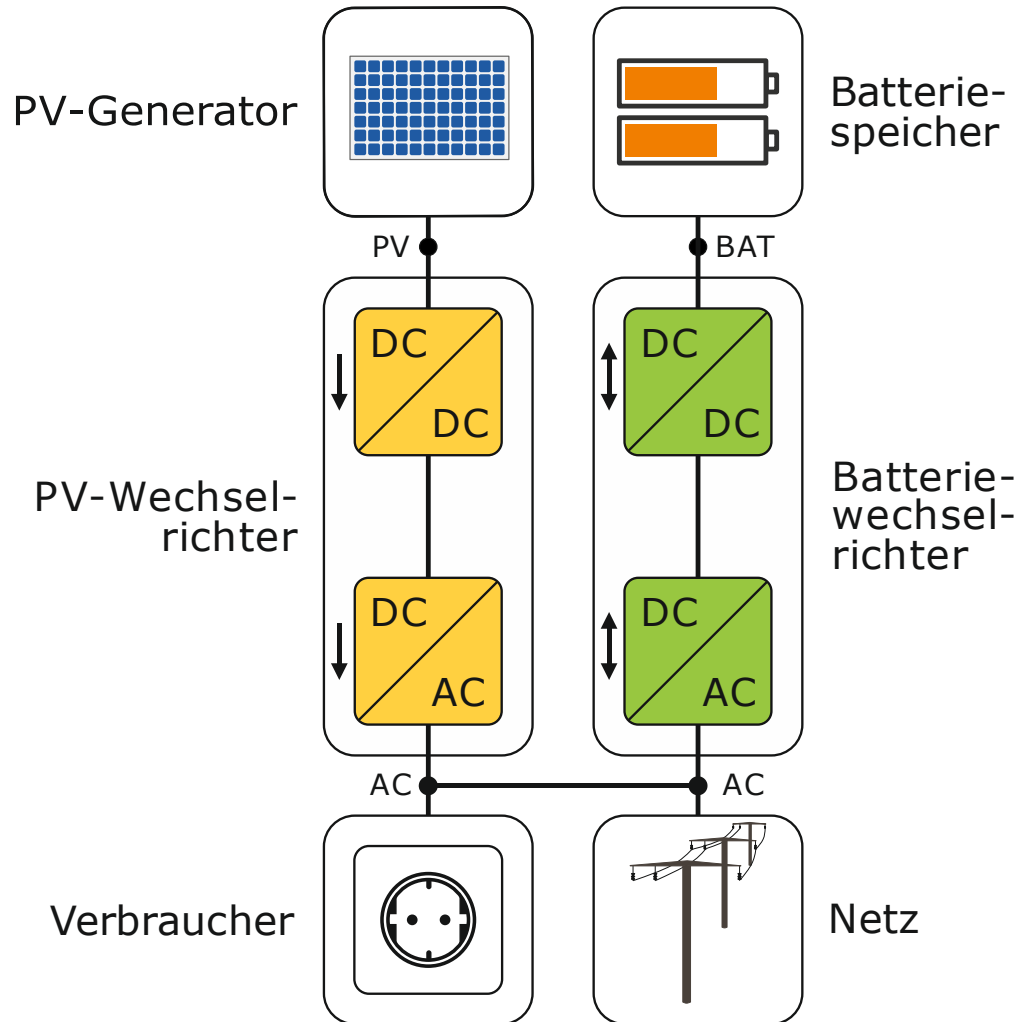

DC-gekoppelte Systeme

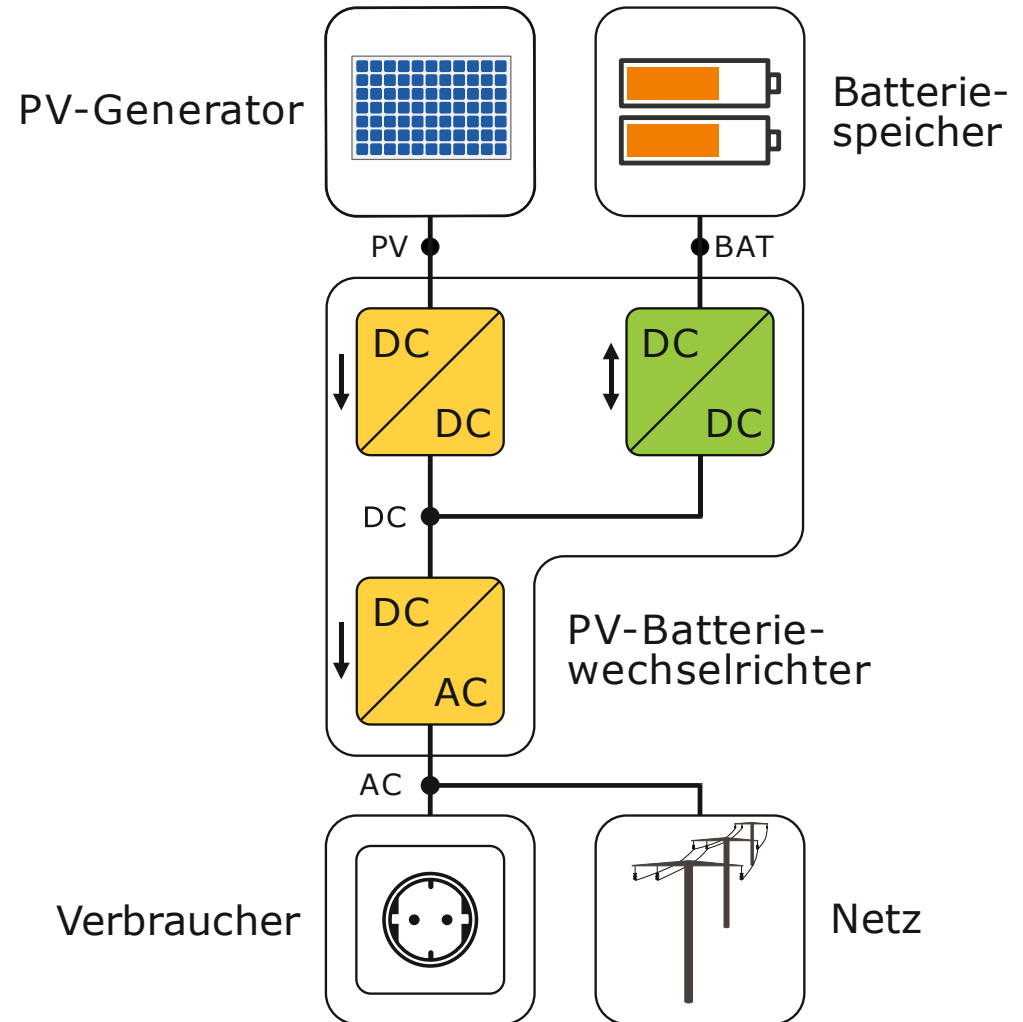

Trend #5 Die Wechselrichter werden leistungstärker

Höhere Batterieeingangsströme



KOSTAL PLENTICORE BI 10/26

26 A

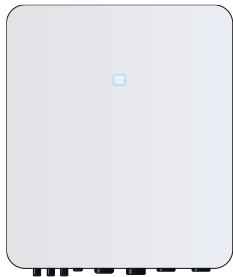

Sungrow SH10RT

30 A

Höhere AC-Nennleistungen

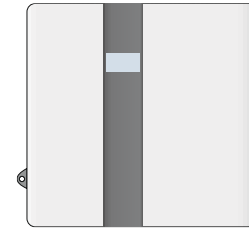

E3/DC S10 E

12 kW

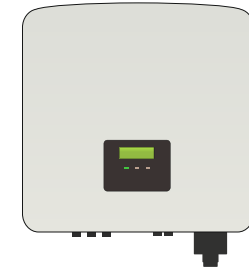

SolaX X3-Hybrid-15.0-D

15 kW



SOFARSOLAR HYD 20KTL-3PH

20 kW

Trend #6 Effizientere Wechselrichter durch Siliziumkarbid-Halbleiter

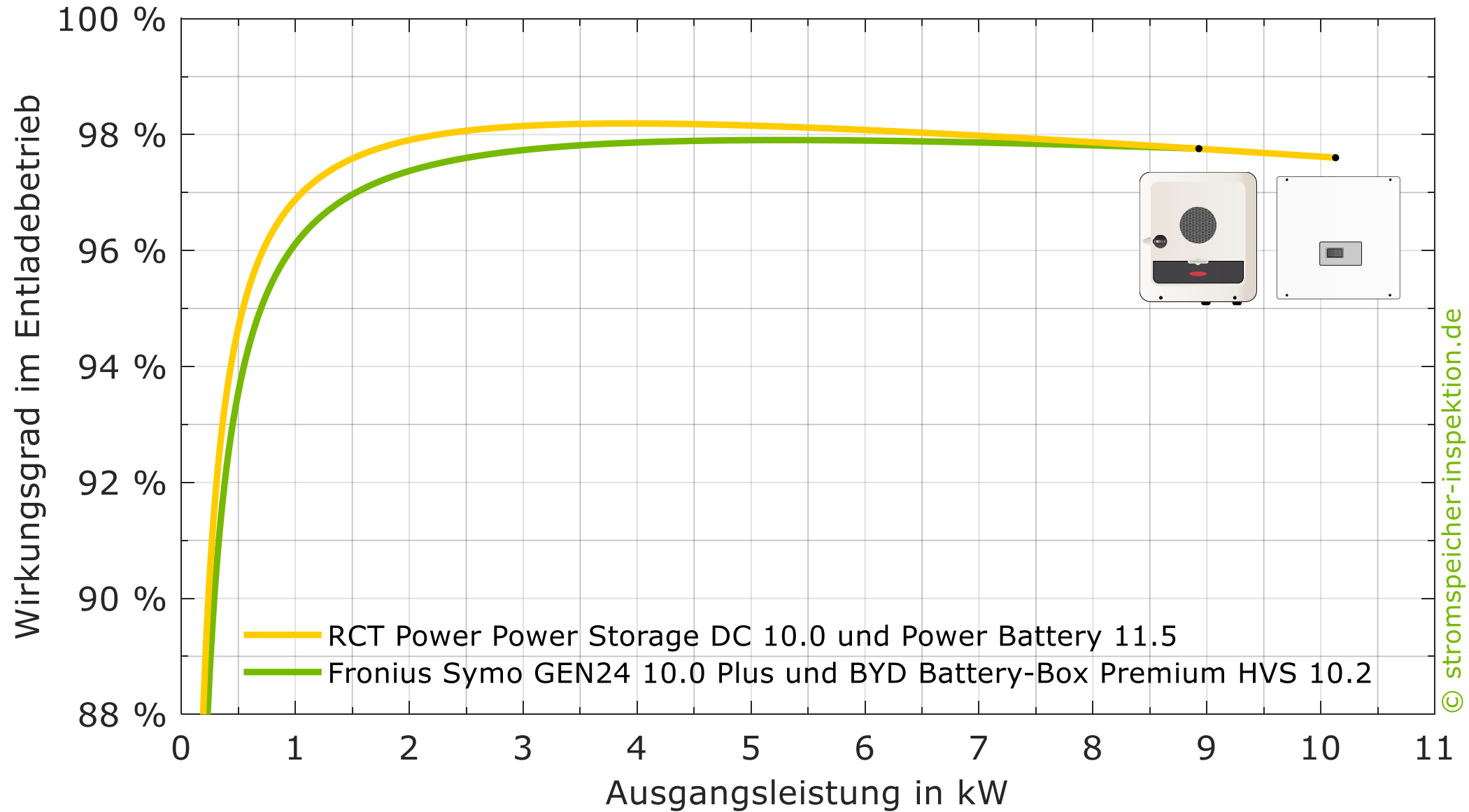

Trend #7 Flexiblere Systemkonzepte sind gefragt

Mehrere unabhängige PV-Eingänge

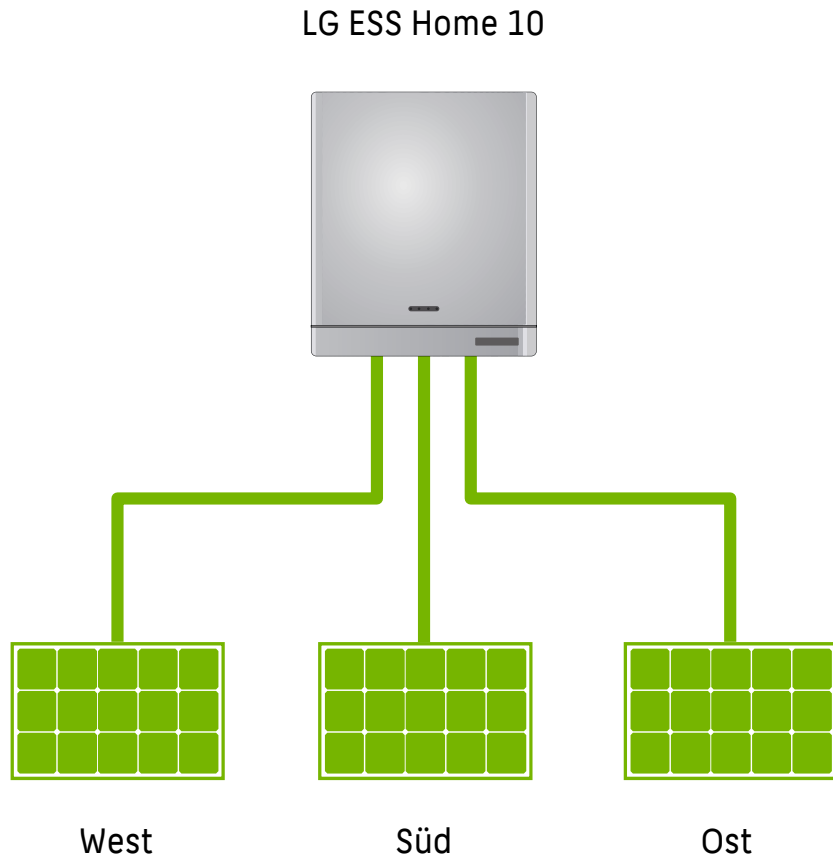

Mehrere unabhängige Batterieeingänge

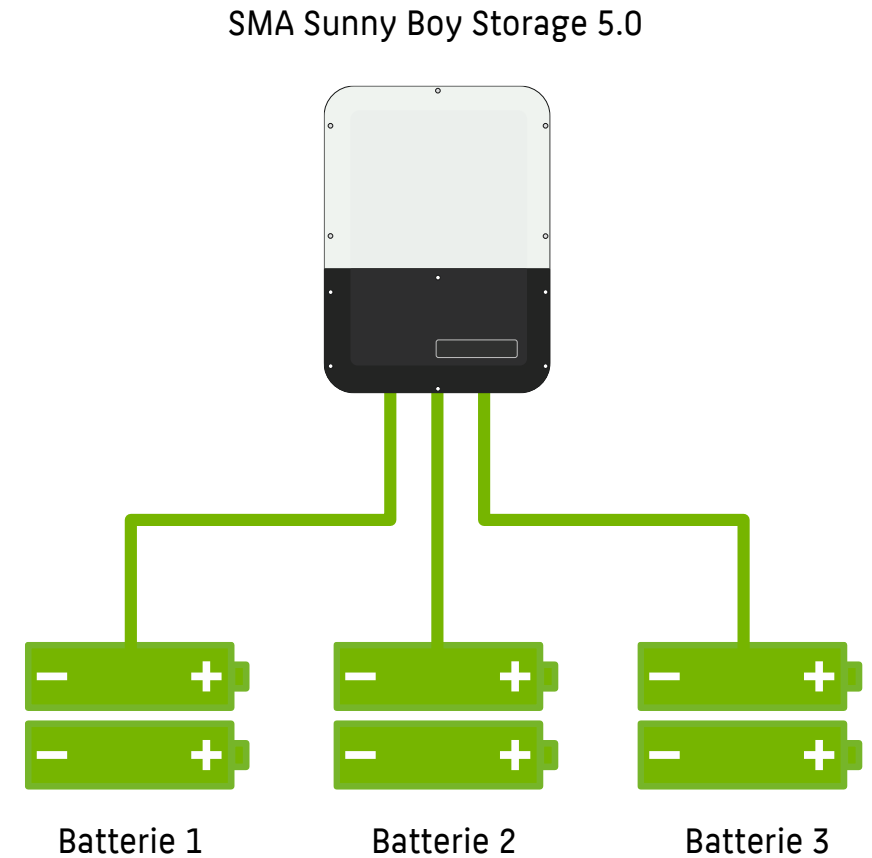

**STROM
SPEICHER**
Inspektion
2022

10 11 12
18/19/20 21 22/23
1 2 3

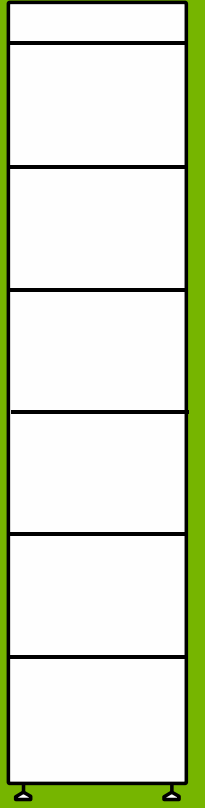
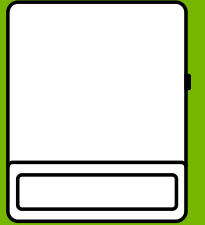
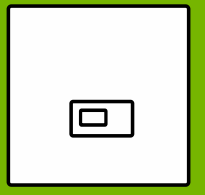
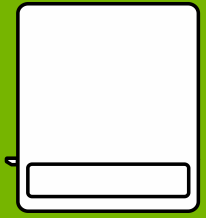
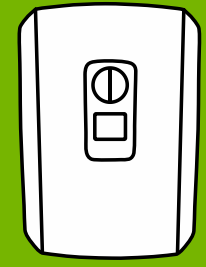
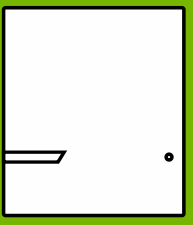
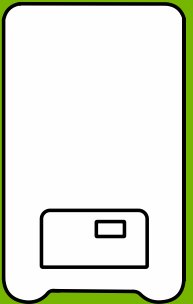
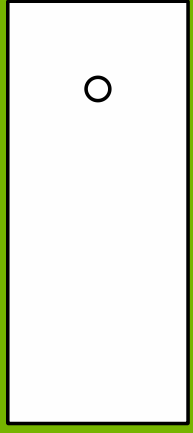
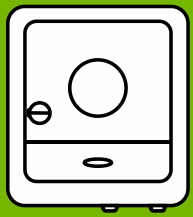
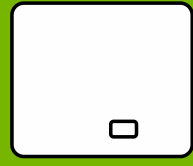
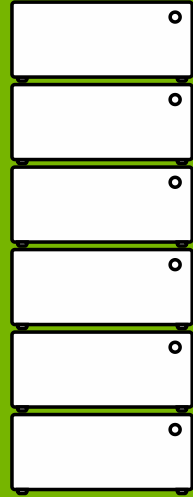
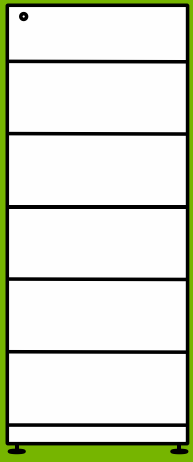
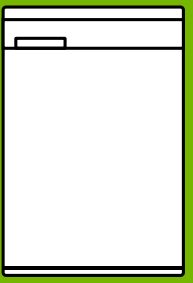
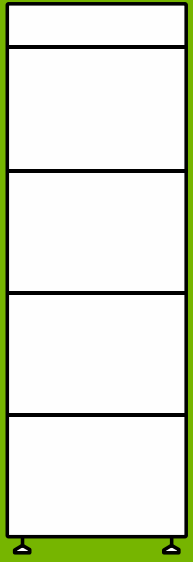
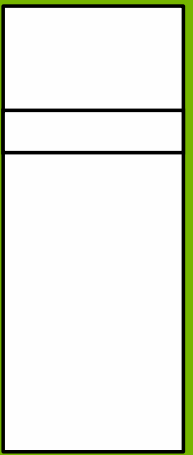

Stromspeicher-Inspektion 2022

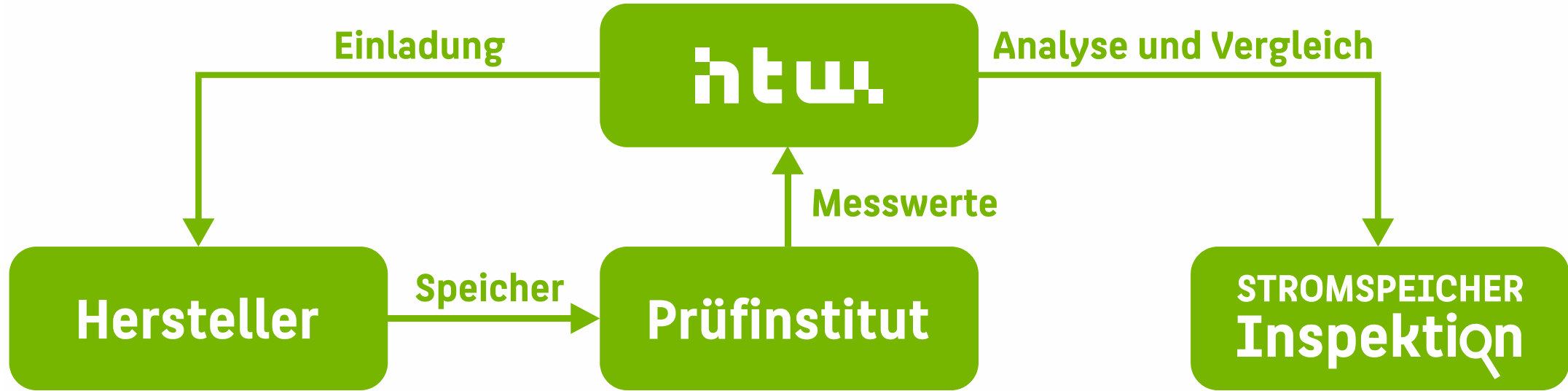

14 Hersteller haben sich mit Messwerten von **21 Stromspeichersystemen** beteiligt.



Systeme der Stromspeicher-Inspektion 2022

- A1** VARTA pulse neo 6
- B1** sonnen sonnenBatterie 10
- C1** KOSTAL PIKO MP plus 4.6-2 (AC) und BYD Battery-Box Premium HVS 7.7
- C2** KOSTAL PLENTICORE BI 10/26 und BYD Battery-Box Premium HVS 12.8
- C3** KOSTAL PIKO MP plus 4.6-2 (DC) und BYD Battery-Box Premium HVS 7.7
- C4** KOSTAL PLENTICORE plus 5.5 und BYD Battery-Box Premium HVS 7.7
- C5** KOSTAL PLENTICORE plus 10 und BYD Battery-Box Premium HVS 12.8
- D1** Fronius Primo GEN24 6.0 Plus und BYD Battery-Box Premium HVS 7.7
- D2** Fronius Symo GEN24 10.0 Plus und BYD Battery-Box Premium HVS 10.2
- E1** GoodWe GW5000-EH und BYD Battery-Box Premium HVS 7.7
- E2** GoodWe GW10K-ET und BYD Battery-Box Premium HVS 12.8
- F1** KACO blueplanet 10.0 TL3 und BYD Battery-Box Premium HVS 10.2
- F2** KACO blueplanet 10.0 TL3 und Energy Depot Domus 2.5
- G1** RCT Power Power Storage DC 6.0 und Power Battery 7.6
- G2** RCT Power Power Storage DC 10.0 und Power Battery 11.5
- H1** VIESSMANN Vitocharge VX3 Typ 4.6A8
- I1** Fenecon Home
- L1** SolaX X3-Hybrid-15.0-D und Triple Power T-BAT H 23.0

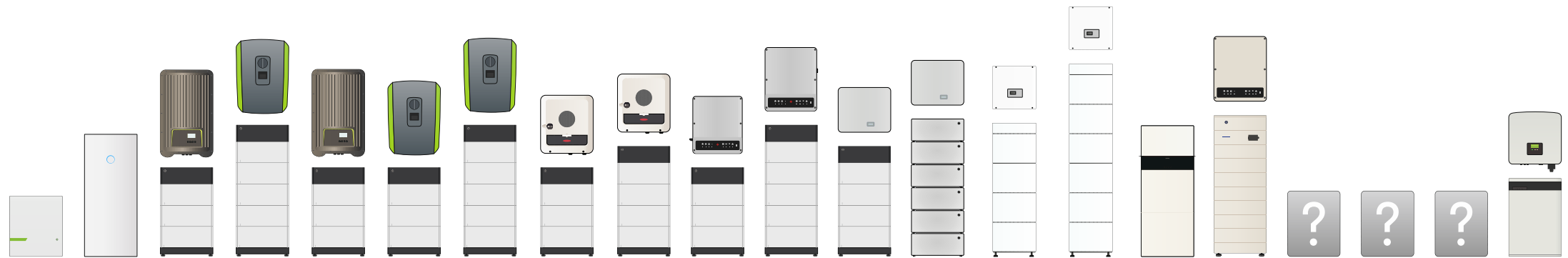

A1 B1 C1 C2 C3 C4 C5 D1 D2 E1 E2 F1 F2 G1 G2 H1 I1 J1 J2 K1 L1

AC-gekoppelte Systeme

DC-gekoppelte Systeme

Vergleich der Datenblattangaben und Labormesswerte

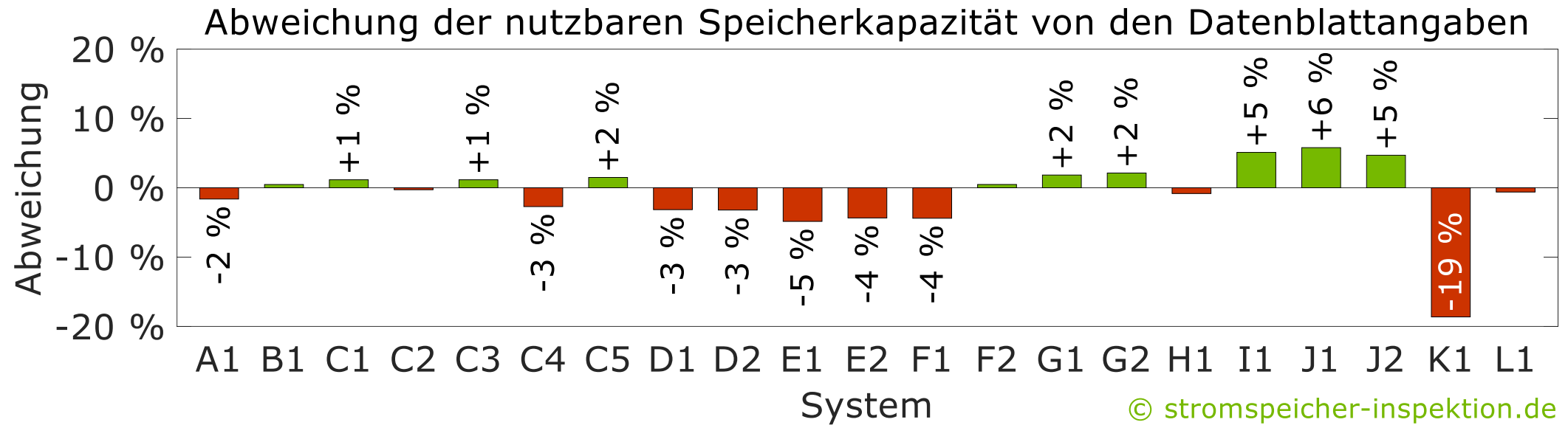

- Die nutzbare Speicherkapazität des Systems K1 liegt um 2,6 kWh (19 %) unter dem auf dem Datenblatt angegebenen Wert.
- Die vorgegebene Entladetiefe zum **Schutz vor Tiefenentladung** ist häufig der Grund dafür, weshalb die Messwerte niedriger als die Datenblattwerte sind.

Bandbreite der wichtigsten Effizienzeigenschaften



© stromspeicher-inspektion.de
STROMSPEICHER
Inspektion

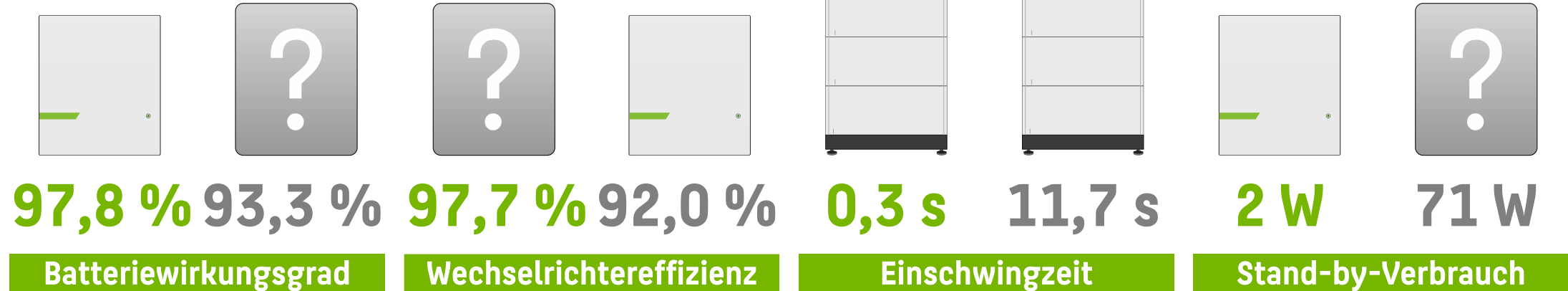

Effizienztestsieger der Stromspeicher-Inspektion 2022

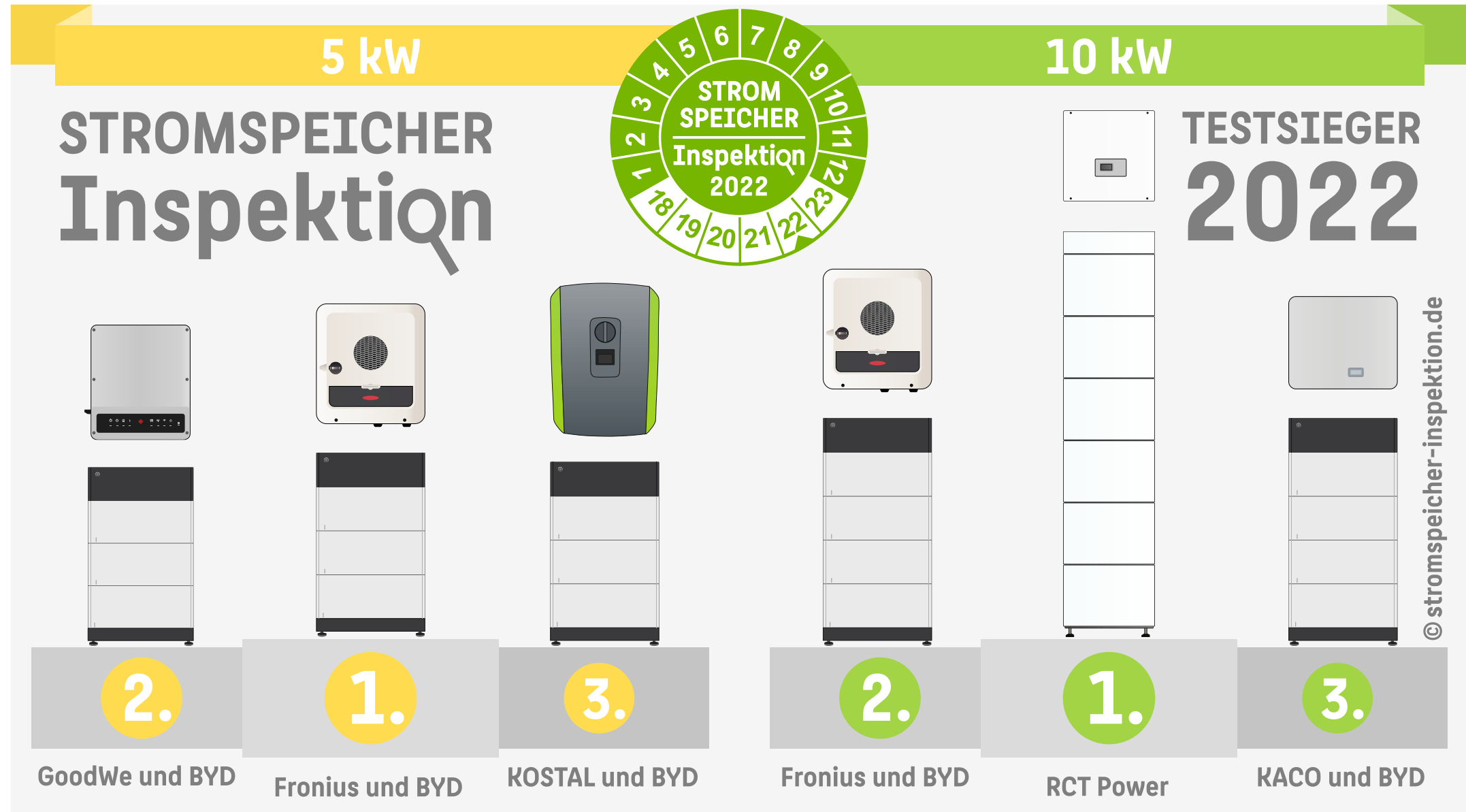

Höhere Eigenversorgung durch effizientere PV-Speichersysteme

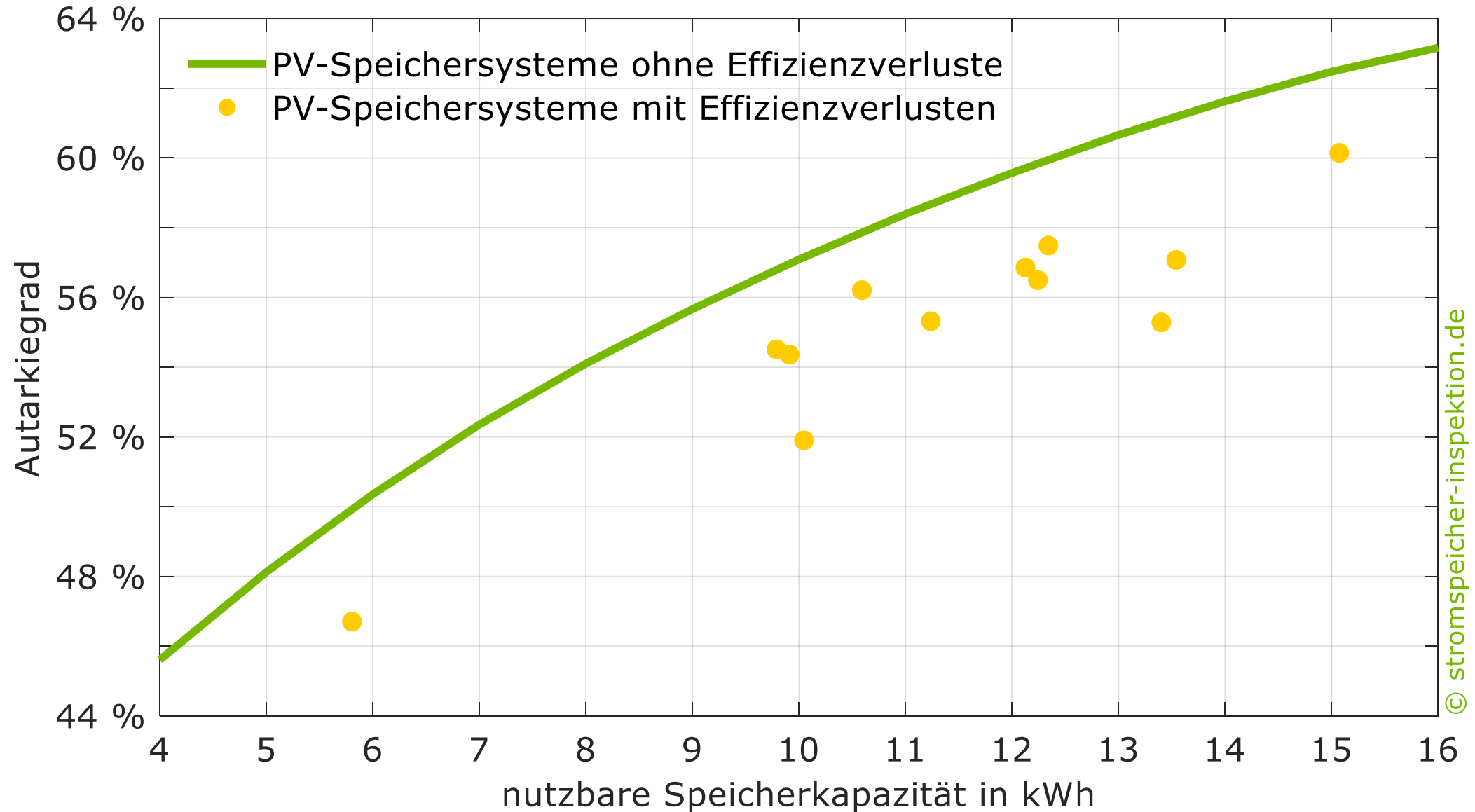

© stromspeicher-inspektion.de

Je größer die PV-Anlage ist, desto mehr CO₂ wird vermieden

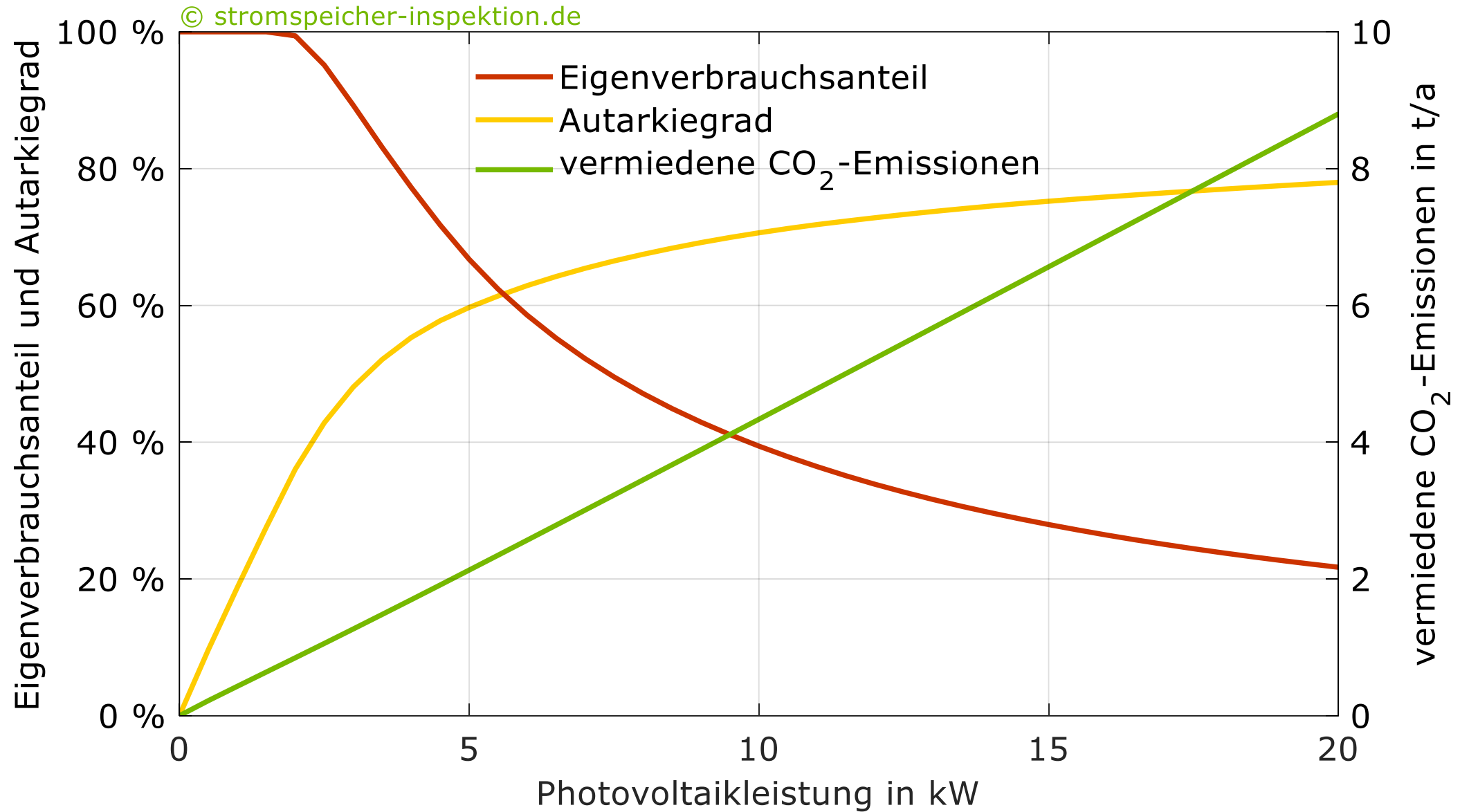

Verbreitung von Klimaschutztechnologien in Deutschland

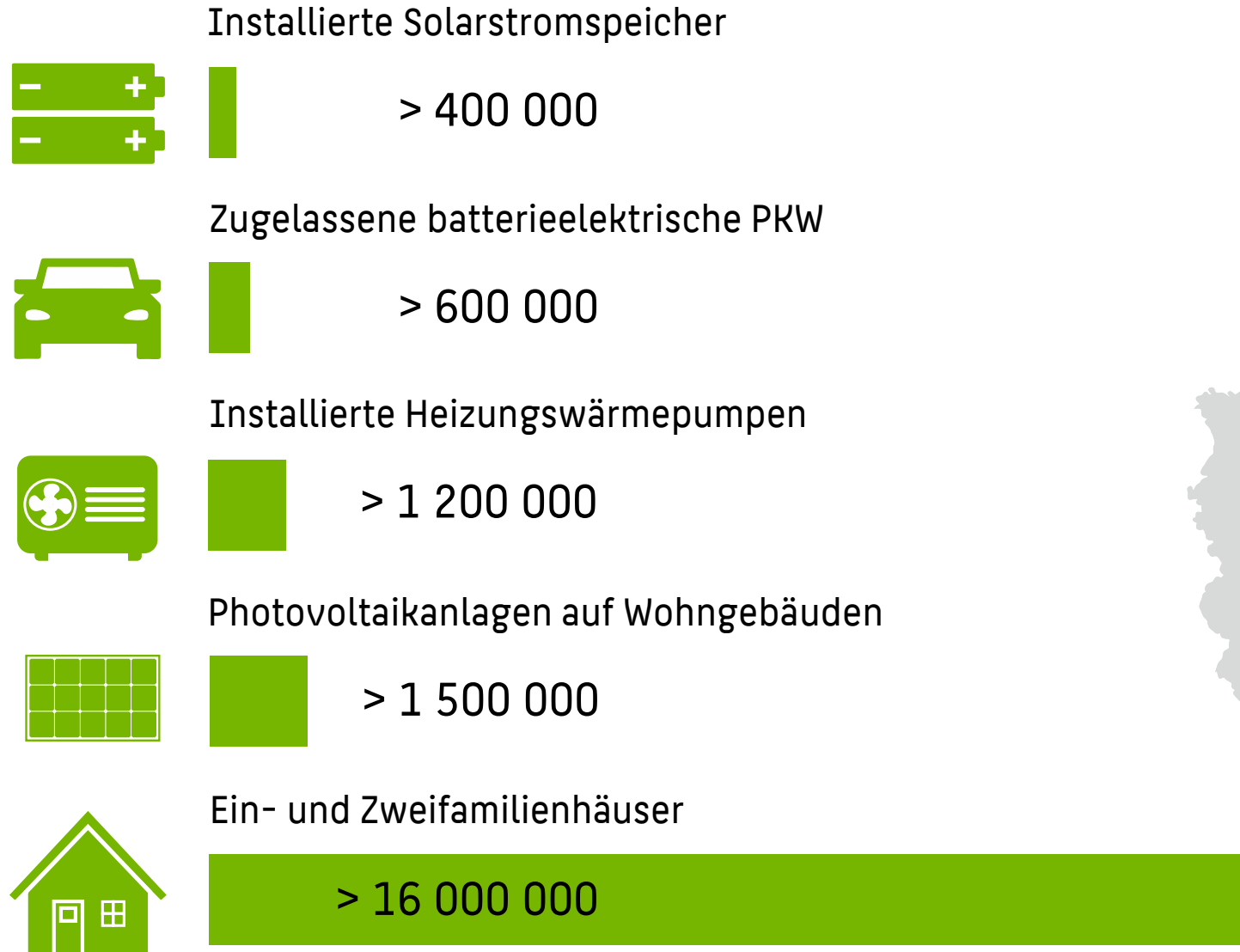

Klimaschutzziele erfordern einen ambitionierten PV-Ausbau

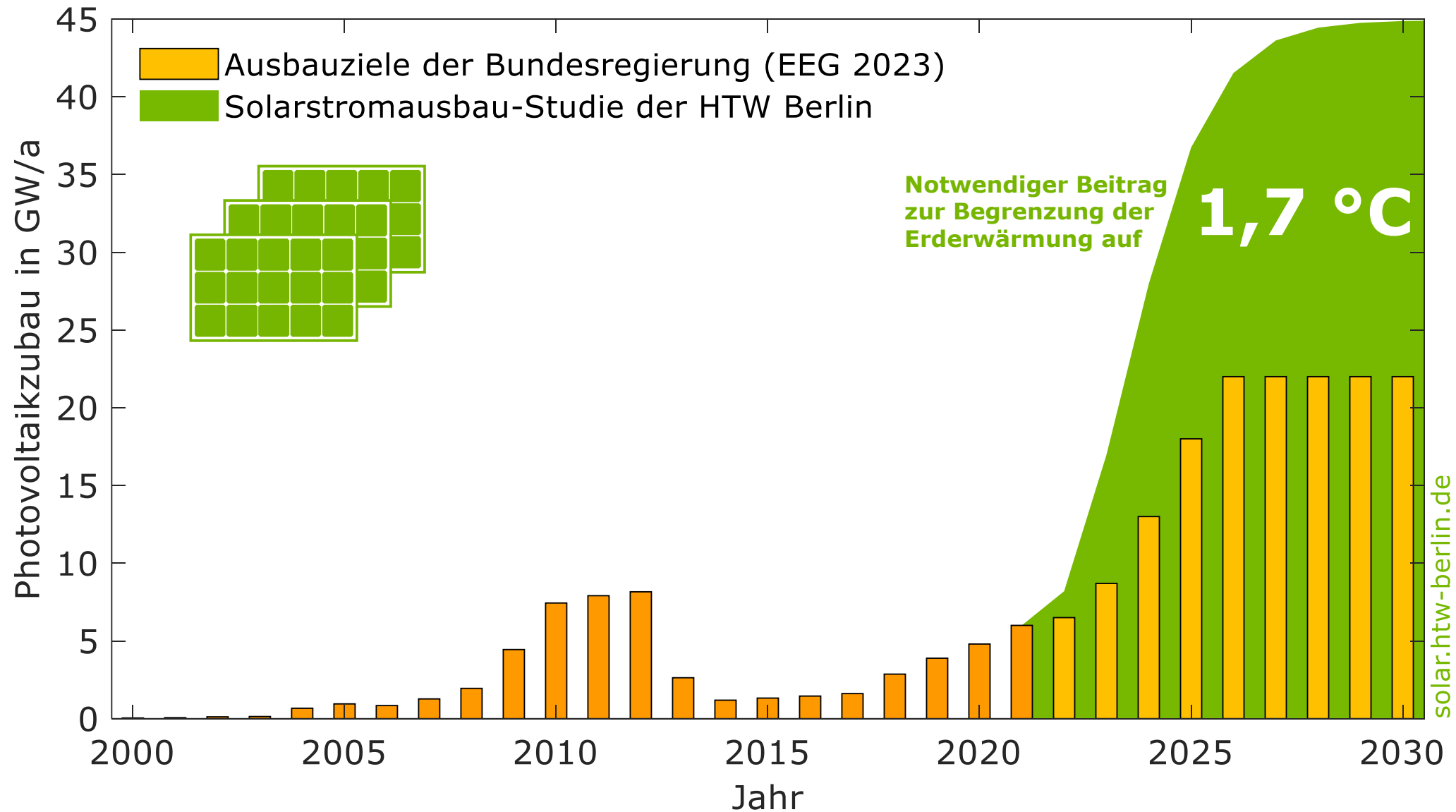

Gefördert durch:



Bundesministerium
für Wirtschaft
und Klimaschutz

aufgrund eines Beschlusses
des Deutschen Bundestages



htw

Hochschule für Technik
und Wirtschaft Berlin

University of Applied Sciences

Johannes Weniger, Nico Orth, Lucas Meissner
Forschungsgruppe Solarspeichersysteme

solar.htw-berlin.de